

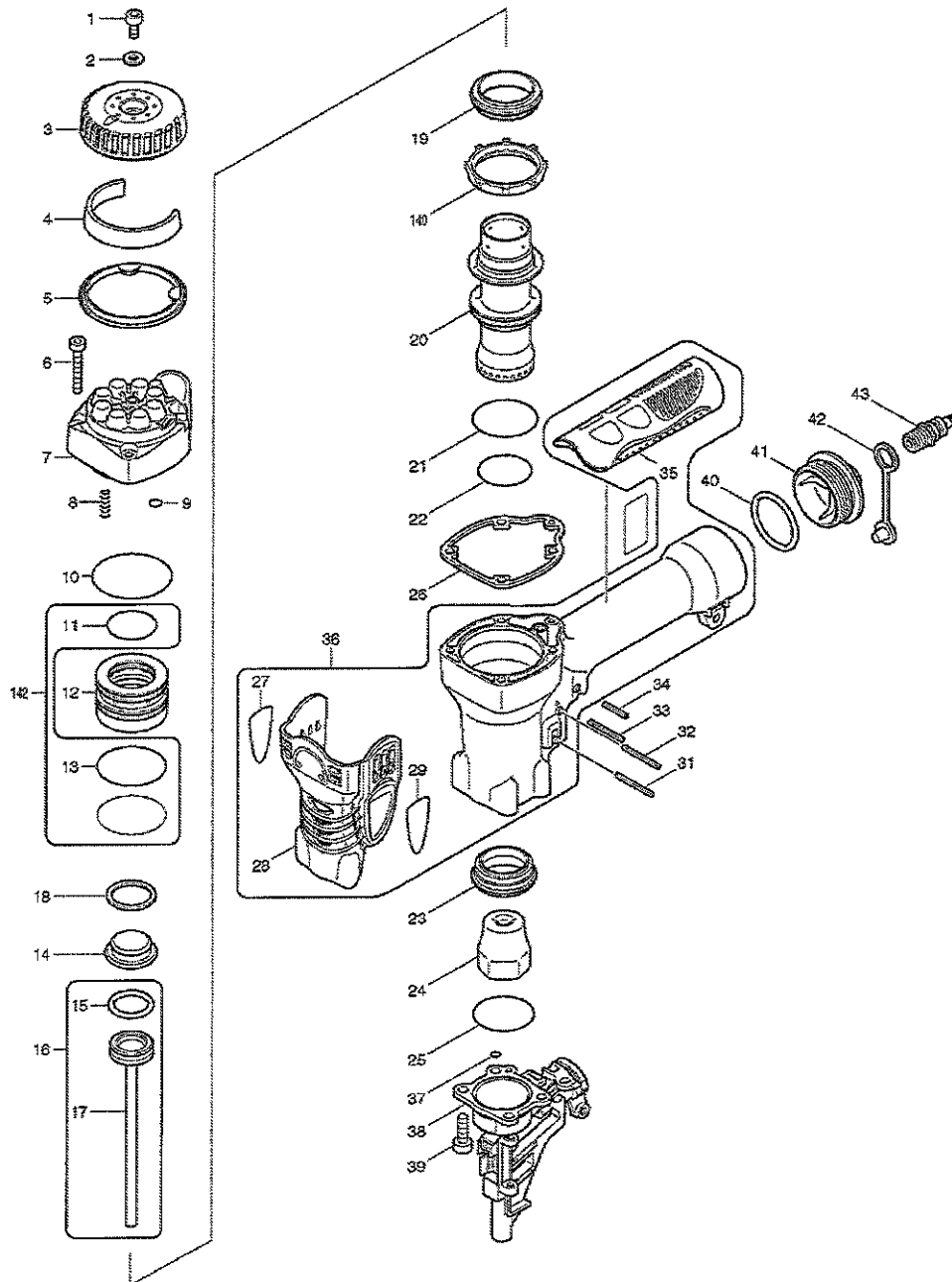

# Makita Service Information / Model: AN620H





# Makita Service Information / Model: AN620H

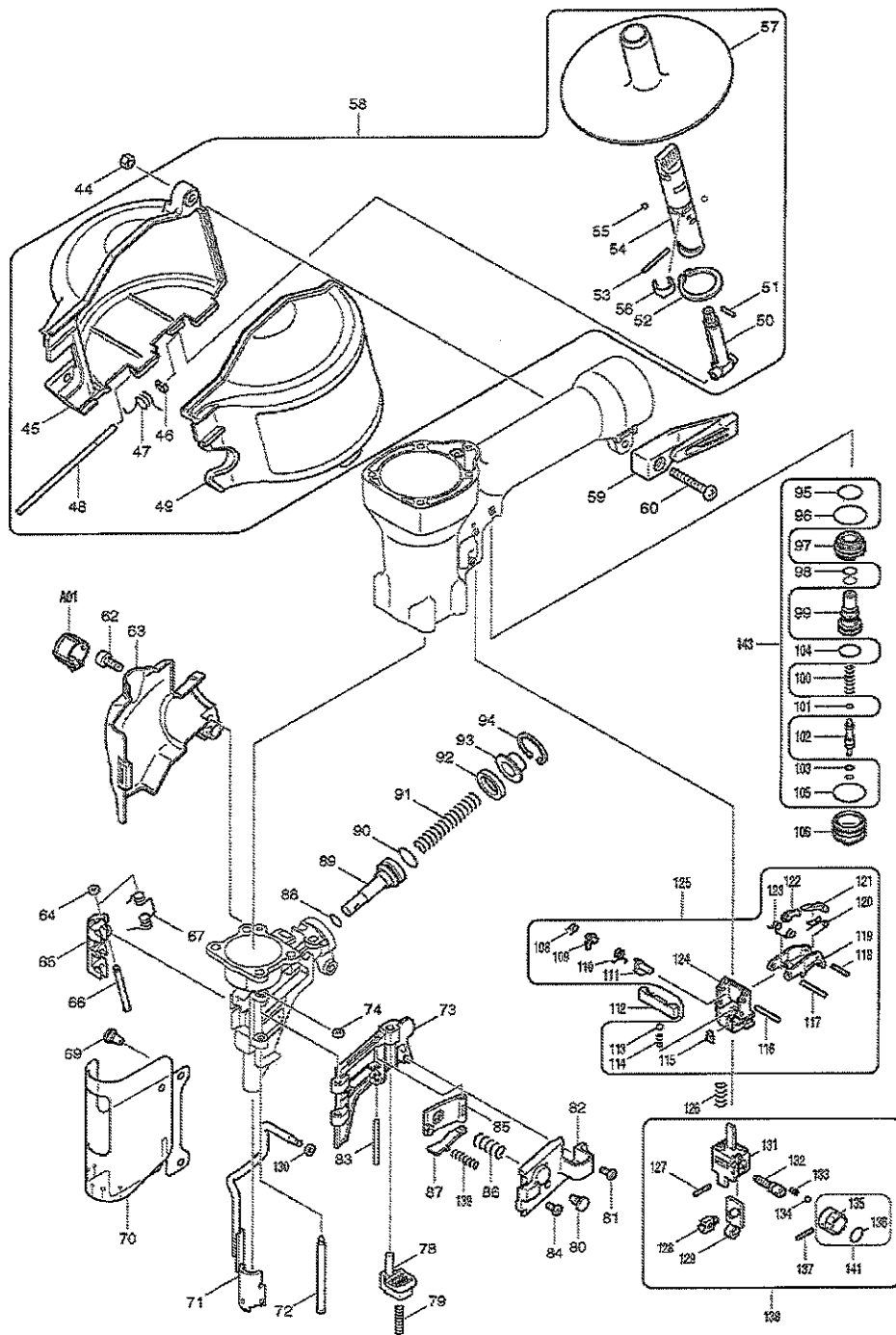



## Makita Service Information / Model: AN620H

POS	Bestell-Nr.	Artikelbeschreibung	Stk.	Stk.Preis
1	922212-4	SECHSKANTSCHRAUBE M5x12	1	N/A
2	267343-5	DISTANZSCHEIBE 5 AN711H/510H	1	N/A
3	419734-8	*ABDECKUNG AN620H/610H	1	N/A
3.2	453875-0	ABDECKUNG AN620H/610H	1	N/A
4	413103-5	FILTER AN620H/610H	1	N/A
5	419735-6	DICHTUNGSDECKEL AN620H/610H	1	N/A
6	922257-2	SCHRAUBE M5X35 AN620H/610H	4	N/A
7	318109-7	KAPPE AN620H/610H	1	N/A
8	233484-9	DRUCKFEDER 4 AN711/450/610/911	8	N/A
9	213021-5	O-RING 5	1	N/A
10	213604-1	O-RING 50	1	N/A
11	213447-1	*O-RING 30 AN620H/450H/610h	1	N/A
11.2	213423-5	O-RING 30 2702/SG1250	1	N/A
12	419736-4	KOPFVENTIL AN620H/450H/610H	1	N/A
13	213558-2	O-RING 42 AN5010/AN620/450/610	2	N/A
14	421983-5	Rückstoßdämpfer AN620H/610H	1	N/A
15	213967-5	O-RING 22.5 AN620H/610H	1	N/A
16	135174-9	KOLBENFÜHRUNG AN620H	1	N/A
16		*** INC. 15,17		N/A
17	168454-8	Stempel AN620H	1	N/A
18	267342-7	SCHEIBE 26 AN620H/450H/610H	1	N/A
19	421981-9	VENTILSITZ AN620H/450H/610H	1	N/A
20	331740-2	*ZYLINDER AN620H/610H	1	N/A
21	213509-5	O-RING 40 AN5010/AN620H/450H	1	N/A
22	213475-6	O-RING 34 AN620H/610H	1	N/A
23	324742-5	ZYLINDERFÜHRUNG AN620H/610H	1	N/A
24	421982-7	DÄMPFER VORNE AN620H/610H	1	N/A
25	213528-1	O-RING 38 AN620H/450H/610H	1	N/A
26	162246-7	Dichtung AN620H/450H/610H	1	N/A
27	819321-7	MAKITA ETIKETTE R AN620H/450H	1	N/A
29	819322-5	MAKITA ETIKETTE L AN620H/450H	1	N/A
31	951078-5	KERBSTIFT AN711H/AN620H/510H	1	N/A
32	951078-5	KERBSTIFT AN711H/AN620H/510H	1	N/A
33	258029-2	KERBSTIFT 3-30 AN620H/610H	1	N/A
34	951069-6	*KERBSTIFT 3-20 AN5010/AN620H	1	N/A
36	188604-9	GEHÄUSE kpl. AN620H/AN450H	1	N/A
36		*** INC. 27,29		N/A
37	213970-6	O-RING 4 AN620H/450H/610H	1	N/A
38	310251-0	Rückstoßdämpferhalter. AN620H	1	N/A
39	922332-4	*Schraube M6x20 LF1000/AN620	4	N/A



## Makita Service Information / Model: AN620H

POS	Bestell-Nr.	Artikelbeschreibung	Stk.	Stk.Preis
40	213521-5	*O-RING 36	1	N/A
40.2	213506-1	O-RING 36 FÜR SCHLAGNUSS 3/4"	1	N/A
41	318108-9	LUFTANSCHLU.DECKEL AN711/AN620	1	N/A
42	286280-4	KAPPE 9 AN711H/AN620H/AN510H	1	N/A
43	243105-5	Schnellkuppl. H22PM/AN711H/620	1	N/A
44	264008-0	MUTTER M5-8 AN620H/AN610H	1	N/A
45	419737-2	*MAGAZIN AN620H/610H	1	N/A
45.2	453103-3	MAGAZINE	1	N/A
46	259042-3	SPERRING E-3 AN711H/AN620H	1	N/A
47	233504-9	RÜCKZUGSSFEDER 8 AN711H/620H	1	N/A
48	256773-5	STIFT 4 AN711H/AN620H/610H	1	N/A
49	158918-0	*MAGAZINKAPPE AN620H	1	N/A
50	419747-9	JUSTIERSCHAFT AN620H/AN610H	1	N/A
51	268166-4	STIFT 2.5 AN620H/610H	1	N/A
52	961105-0	SEEGERING S-25	1	N/A
53	268167-2	STIFT 2.5 AN620H/AN510H/610H	1	N/A
54	419746-1	TIEFENEINSTELLHÜLSE AN620/610H	1	N/A
55	216001-0	STAHLKUGEL 3.5	2	N/A
56	232233-1	BLATTFEDER	1	N/A
57	419745-3	UMSCHALTPLATTE AN620H/610H	1	N/A
58	135256-7	*Magazin kpl. AN620H	1	N/A
58		*** INC. 45-57		N/A
58.2	135499-1	MAGAZINE ASSY	1	N/A
58.2		*** INC. 45-57		N/A
59	419739-8	HAKEN AN620H/610H	1	N/A
60	911257-7	SCHRAUBE M5x35 AN620H/610H	1	N/A
60.2	911258-5	SCHRAUBE M5x35	1	N/A
62	922212-4	SECHSKANTSCHRAUBE M5x12	1	N/A
63	419740-3	KONTAKTARMDECKEL AN620H	1	N/A
64	262120-0	RING 3 AN711H/AN620H/AN510H	1	N/A
65	310195-4	VORSCHUB AN620H	1	N/A
66	268165-6	Stift 4.5 AN620H	1	N/A
67	231632-4	RÜCKZUGSFEDER 6 AN610H	1	N/A
69	421418-6	GUMMISTIFT 9.5 AN923/943/620	1	N/A
70	413104-3	DECKEL AN620H	1	N/A
71	165492-1	KONTAKTARM AN620H	1	N/A
72	256772-7	STIFT 4 AN620H	1	N/A
73	310193-8	AUSSTOSSÖFFNUNG AN620H	1	N/A
74	262120-0	RING 3 AN711H/AN620H/AN510H	1	N/A
78	162247-5	SPERRHEBEL AN620H/AN510H	1	N/A



## Makita Service Information / Model: AN620H

POS	Bestell-Nr.	Artikelbeschreibung	Stk.	Stk.Preis
79	233486-5	DRUCKFEDER 5 AN711H/911H	1	N/A
80	421418-6	GUMMISTIFT 9.5 AN923/943/620	1	N/A
81	266419-5	INBUSSCHRAUBE M4x12 AN620H	1	N/A
82	419741-1	Verschlußdeck.f.Aufnahme AN620	1	N/A
83	268164-8	STIFT 3 AN620H	1	N/A
84	266419-5	INBUSSCHRAUBE M4x12 AN620H	1	N/A
85	310194-6	NAGELHALTERUNG AN620H	1	N/A
86	233487-3	DRUCKFEDER 8 AN620H	1	N/A
87	345774-9	SICHERUNG AN620H	1	N/A
88	213054-0	O-RING 9 5014NB/AN711H/AN620	1	N/A
89	324744-1	KOLBEN AN620H	1	N/A
90	213154-6	O-RING 14 KP312S/AN711/AN620	1	N/A
91	233198-0	DRUCKFEDER 9 AN621/AN620H	1	N/A
92	262075-9	GUMMIRING 16 AN620H/AN450H	1	N/A
93	344452-8	SCHEIBE 5 AN620H	1	N/A
94	962103-7	*SICHERUNGSRING	1	N/A
95	213233-0	O-RING 15 AN711H/AN610H/AN510	1	N/A
96	213275-4	*O-RING 18 BFL400F/HR4011	1	N/A
97	419732-2	VENTILANSCHLAG AN510H/AN610H	1	N/A
98	213968-3	O-RING 7 AN711H/AN610H/AN510H	2	N/A
99	419733-0	*STEUERVENTIL AN610H/AN510H	1	N/A
100	233485-7	DRUCKFEDER 4 AN510H/AN620H	1	N/A
101	213034-6	O-RING 3 DA3010F/DA3011F/JR1	1	N/A
101.2	213044-3	O-RING 3 AN923/943	1	N/A
102	324743-3	*VENTILSTIFT AN711H/AN620H/510	1	N/A
102.2	326189-9	VENTILSTIFT AN711H/AN620H/510H	1	N/A
103	213979-8	*O-RING 3 AN711H/AN620H/AN510	2	N/A
103.2	213640-7	O-RING 3 AN711H/AN620H/AN510H	2	N/A
104	213185-5	O-RING 12.5 AN620H/AN711H/510H	1	N/A
105	213275-4	*O-RING 18 BFL400F/HR4011	1	N/A
106	331741-0	VENTILGEHÄUSE AN711H/620H/510H	1	N/A
108	233501-5	RÜCKZUGFEDER 5 AN711H/620H/510	1	N/A
109	310199-6	STOP-PLATTE AN711H/620H/510H	1	N/A
110	233502-3	*RÜCKZUGSFEDER 6 AN711H/AN620	1	N/A
110.2	233576-4	RÜCKZUGSFEDER 6 AN711H/AN620H	1	N/A
111	310310-0	HEBEL AN711H/620H/510H	1	N/A
112	310293-4	JUSTIERSTIFT AN711H/620H/510H	1	N/A
113	216024-8	STAHLKUGEL 4 BFL080F/DFL650F	1	N/A
113.2	326144-1	KUGELPIN AN911H	1	N/A
114	233490-4	DRUCKFEDER 2 AN711H/620H/510H	1	N/A



## Makita Service Information / Model: AN620H

POS	Bestell-Nr.	Artikelbeschreibung	Stk.	Stk.Preis
115	419743-7	FEDERABDECKUNG AN620H/711H/510	1	N/A
116	268168-0	STIFT 3 AN711H/AN620H/AN510H	1	N/A
117	268168-0	STIFT 3 AN711H/AN620H/AN510H	1	N/A
118	951007-8	KERBSTIFT 2-12 AN711H/AN620H	1	N/A
119	310294-2	EINSCHALTER AN711H/620H/510H	1	N/A
120	231699-2	RÜCKZUGSSFEDER 4 AN711H/620H	1	N/A
121	310196-2	TRIP LEVER AN711H/620H/510H	1	N/A
122	310198-8	HEBEL AN711H/AN620H/AN510H	1	N/A
123	233503-1	RÜCKZUGSSFEDER 4 AN711H/AN620H	1	N/A
124	419844-1	VENTIL AN711H/AN620H/AN510H	1	N/A
125	135231-3	*EINSCHALTER AN510H/AN711H	1	N/A
125		*** INC. 108-111,113-124		N/A
125.2	135494-1	EINSCHALTER AN911H	1	N/A
125.2		*** INC. 108-111,113-124		N/A
126	233489-9	DRUCKFEDER 6 AN711H/AN620H	1	N/A
127	951010-9	*KERBSTIFT 2-14(AN5010)AN711H	1	N/A
128	310201-5	Einstellstück AN711H/620H/510H	1	N/A
129	345775-7	GLEITPLATTE AN620H/AN510H/450H	1	N/A
130	262120-0	RING 3 AN711H/AN620H/AN510H	1	N/A
131	310234-0	UPPER YORK AN620H/AN510H/450H	1	N/A
132	324745-9	JUSTIERSCHAFT AN620H/AN510H	1	N/A
133	233491-2	DRUCKFEDER 2 AN711H/620H/510H	1	N/A
134	216031-1	STAHLKUGEL 2.3 AN711H/620H/510	1	N/A
137	951010-9	*KERBSTIFT 2-14(AN5010)AN711H	1	N/A
138	135232-1	EINSTELLRING AN620H/AN510H	1	N/A
138		*** INC. 127-129,131-134,137,141		N/A
139	233488-1	DRUCKFEDER 5 AN620H	1	N/A
140	331739-7	ZYLINDERHALTER AN620H/450H	1	N/A
141	158747-1	Einstellring AN711H/620H/510H	1	N/A
142	194735-4	LUFTVERLUST REP. SET AN620/450	1	N/A
142		*** INC. 11,13,143		N/A
143	194735-4	LUFTVERLUST REP. SET AN620/450	1	N/A
143		*** INC. 95,96,98,101,103-105,142		N/A
144	866119-3	TYPENSCHILD AN620H	1	N/A
145	135598-9	TRIGGER VALVE ASS'Y	1	N/A
145		*** INC. 95-106		N/A
1001	421984-3	Adapter AN620H	1	N/A
1002	192517-8	*SCHUTZBRILLE AN923/943/BST22	1	N/A
1002.2	195246-2	*SCHUTZBRILLE	1	N/A
1003	194381-3	*ÖL AN711H/AN620H/AN510H	1	N/A



## Makita Service Information / Model: AN620H

POS	Bestell-Nr.	Artikelbeschreibung	Stk.	Stk.Preis
1004	824490-1	*PVC-KOFFER AN620H	1	N/A