



PSN90 & PSN100

Operating Instructions



CONSTRUCTION PRODUCTS

PSN90

501560

Strip Nailer

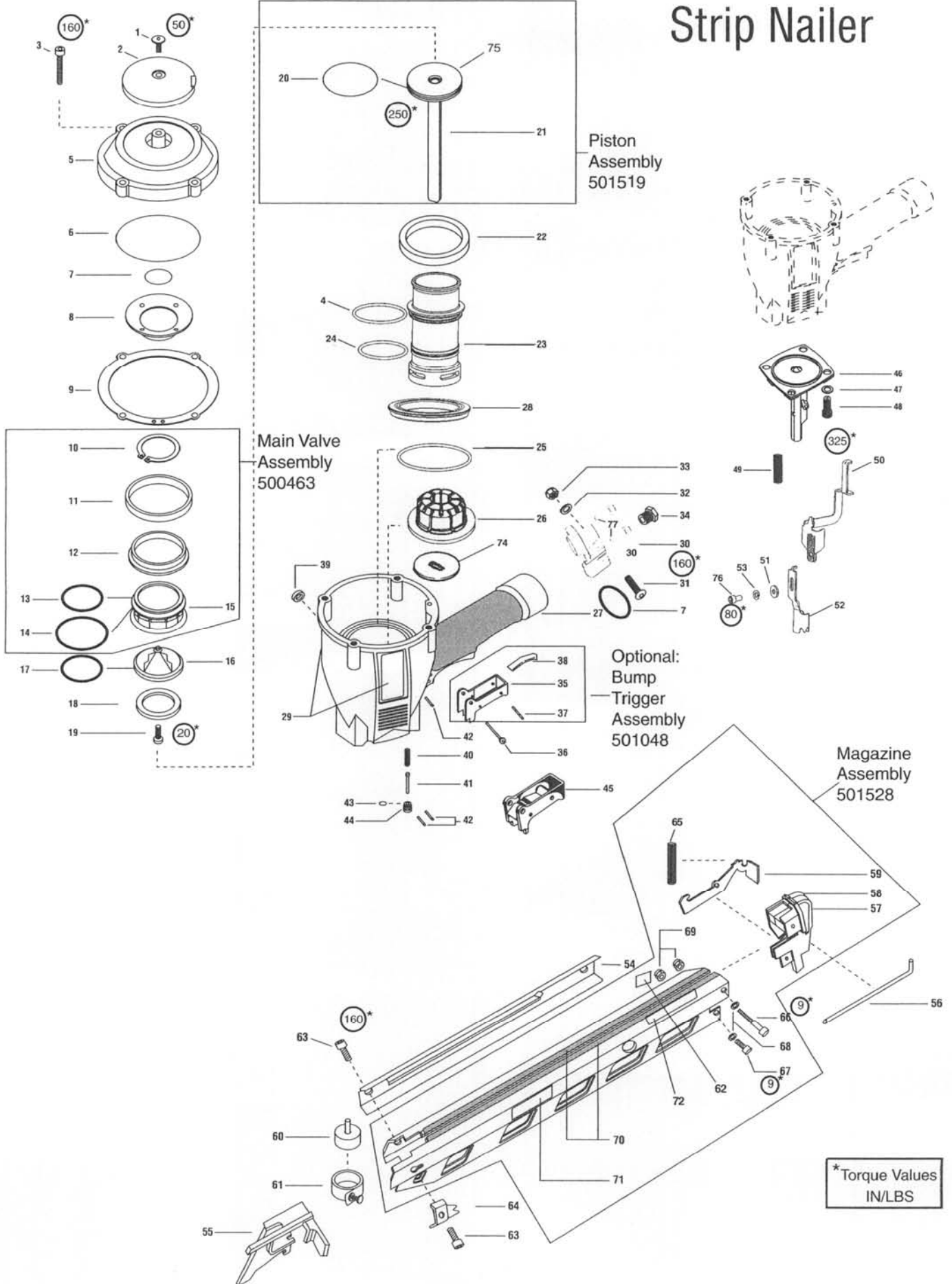

Ref. No.	Part No.	Qty	Description
1	501043	1	T.H.S.C.S. 1/4 -20 x 1/2"
2	501016	1	Air Deflector
3	501300	4	S.H.C.S. 1/4-20 x 1-1/4"
4	500249	1	O-Ring, Sleeve
5	501017	1	Cap
6	500461	1	O-Ring
7	092042	2	O-Ring
8	500407	1	Spring, Main Valve
9	501001	1	Gasket, Cap
10	406041	1	Retaining Ring
11	500455	1	Upper Valve Piston
12	401946	1	Seal, Main Valve
13	091208	1	O-Ring
14	401950	1	O-Ring
15	500456	1	Lower Valve Piston
16	500454	1	Post
17	095432	1	O-Ring
18	500453	1	Bumper, Post
19	402906	1	B.H.S.C.S.10-32 x 5/8"
20	092971	1	O-Ring, Piston
21	501218	1	Driver Blade
22	402011	1	Seal Sleeve
23	501283	1	Sleeve
24	092235	1	O-Ring, Sleeve
25	501002	1	O-Ring
26	500866	1	Bumper
27	501286	1	Housing
28	500779	1	Flange, Sleeve
29	501333	1	Label, Housing - Left
	501334	1	Label, Housing - Right
30	501219	1	End Cap, Housing
31	500516	1	B.H.S.C.S. - Special
32	404274	1	Flat Washer
33	500525	1	Locknut, 5/16-24
34	091622	1	Reducing Pipe Bushing
35	501010	1	Bump Trigger
36	402669	1	Pin, Trigger
37	501009	1	Spirol Pin
38	501008	1	Lever, Bottom Trip
39	402668	1	Retaining Ring
40	097748	1	Spring, Valve Pin
41	097746	1	Valve Pin
42	071297	3	Roll Pin 1/8 x 1-1/8"
43	092174	1	O-Ring, Valve Body
44	401958	1	Valve Body
45	501039	1	Sequential Trigger

Ref. No.	Part No.	Qty	Description
46	501052	1	Nose 30°
47	095417	4	Lockwasher 5/16
48	009016	4	S.H.C.S. 5/16-18 x 1"
49	501006	1	Spring, W.C.E.
50	501363	1	Upper W.C.E.
51	404800	1	Washer, W.C.E.
52	500731	1	Lower W.C.E.
53	002187	1	Lock Washer
54	500717	1	Nail Cover
55	500531	1	Follower
56	501044	1	3/16 Hex Key, Long Arm
57	501024	1	End Cap, Magazine-LF
58	501025	1	End Cap, Magazine-RT
59	501027	1	Latch
60	501046	1	Drum Pin Assembly
61	500513	1	Negator Assembly
62	501524	1	Nameplate
63	404904	2	Screw 1/4-28 x 5/8"
64	500509	1	Front Bracket
65	501028	1	Spring, Latch
66	501026	1	S.H.C.S. 8-32 x 2"
67	066840	1	S.H.C.S. 8-32 x 3/4"
68	404414	2	Flatwasher #8
69	404325	2	Stop Nut
70	500520	2	Wear Strip
71	500458	1	Warning Label
72	501055	1	Logo Label
74	500729	1	Blade Seal
75	501337	1	Piston
76	091618	1	S.H.C.S. 1/4-20 x 1/2"
77	501299	2	S.H.C.S. 1/4-20 x 1"

PSN100

500705



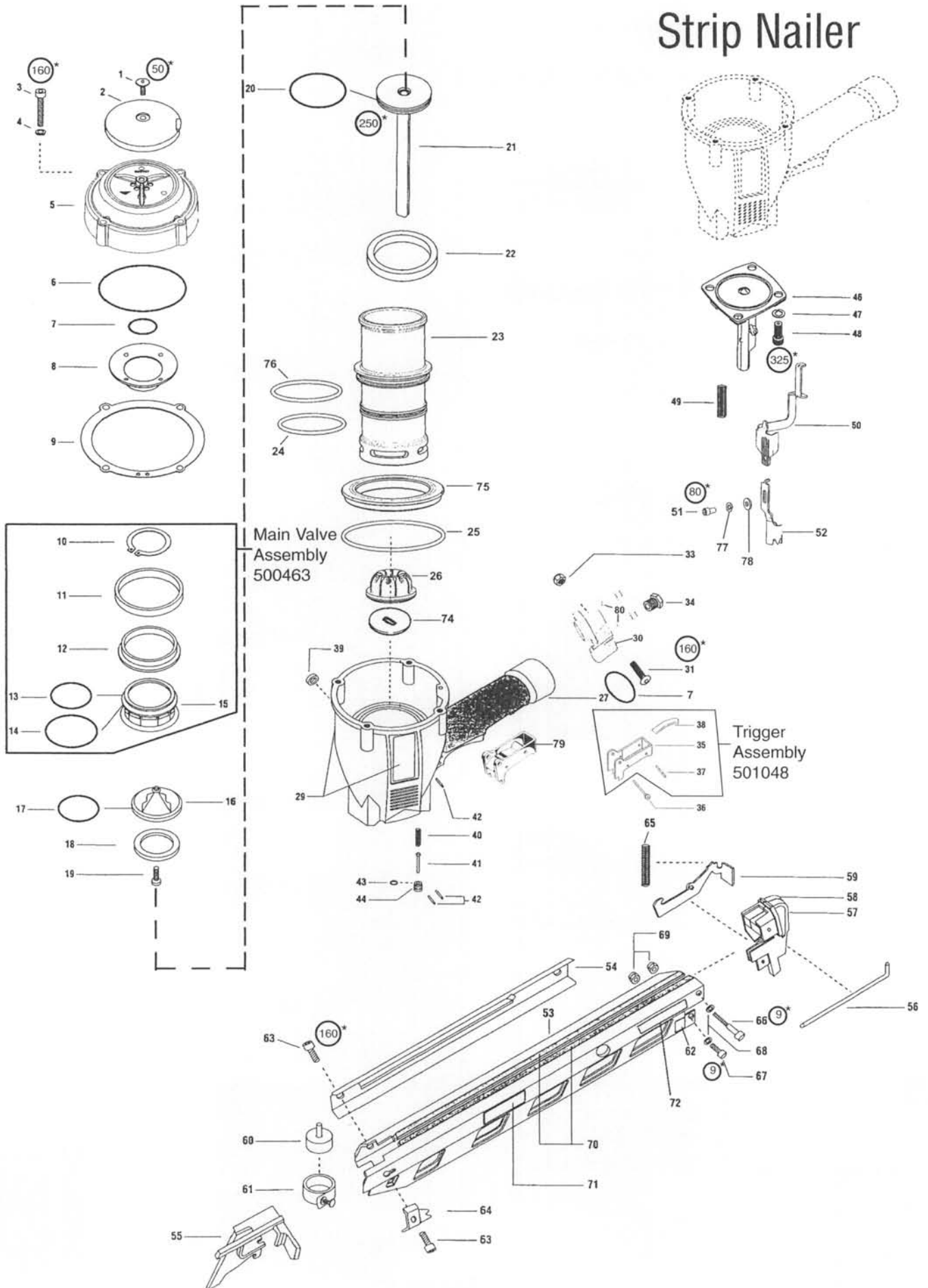

Strip Nailer

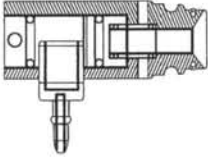

Ref. No.	Part No.	Qty	Description
1	501043	1	T.H.S.C.S. 1/4 -20 x 1/2"
2	501016	1	Air Deflector
3	091873	4	S.H.C.S. 1/4-20 x 2"
4	092757	4	Flatwasher 1/4"
5	500707	1	Cap
6	500461	1	O-Ring
7	092042	2	O-Ring
8	500407	1	Spring, Main Valve
9	501001	1	Gasket, Cap
10	406041	1	Retaining Ring
11	500455	1	Upper Valve Piston
12	401946	1	Seal, Main Valve
13	091208	1	O-Ring
14	401950	1	O-Ring
15	500456	1	Lower Valve Piston
16	500454	1	Post
17	095432	1	O-Ring
18	500453	1	Bumper, Post
19	402906	1	B.H.S.C.S.10-32 x 5/8"
20	092971	1	O-Ring, Piston
21	500709	1	Piston Assembly
22	402011	1	Seal Sleeve
23	500710	1	Sleeve
24	092235	1	O-Ring, Sleeve
25	501002	1	O-Ring
26	500866	1	Bumper
27	501286	1	Housing
29	501333	1	Label, Housing-Leftside
	501334	1	Label, Housing-Rightside
30	501219	1	End Cap, Housing
31	500516	1	B.H.S.C.S. - Special
32	404274	1	Flatwasher
33	500525	1	Locknut, 5/16-24
34	091622	1	Reducing Pipe Bushing
35	501010	1	Trigger
36	402669	1	Pin, Trigger
37	501009	1	Spirol Pin
38	501008	1	Lever, Bottom Trip
39	402668	1	Retaining Ring
40	097748	1	Spring, Valve Pin
41	097746	1	Valve Pin
42	071297	3	Roll Pin 1/8 x 1-1/8"
43	092174	1	O-Ring, Valve Body
44	401958	1	Valve Body
46	500712	1	Nose 30°
47	095417	4	Lockwasher 5/16

Ref. No.	Part No.	Qty	Description
48	009016	4	S.H.C.S. 5/16-18 x 1"
49	501006	1	Spring, W.C.E.
50	501363	1	Upper W.C.E.
51	091618	1	S.H.C.S. 1/4-20 x 1/2"
52	500713	1	Lower W.C.E.
53	501491	1	Magazine with Wear Strips
54	500717	1	Nail Cover
55	500531	1	Follower
56	501044	1	3/16 Hex Key, Long Arm
57	501024	1	End Cap, Magazine-LF
58	501025	1	End Cap, Magazine-RT
59	501027	1	Latch
60	501046	1	Drum Pin Assembly
61	500513	1	Negator Assembly
62	500839	1	Nameplate
63	404904	2	Screw 1/4-28 x 5/8"
64	500509	1	Front Bracket
65	501028	1	Spring, Latch
66	501026	1	S.H.C.S. 8-32 x 2"
67	066840	1	S.H.C.S. 8-32 x 3/4"
68	404414	2	Flatwasher #8
69	404325	2	Stop Nut
70	500520	2	Wear Strip
71	500458	1	Warning Label
72	500838	2	Logo Label
74	500729	1	Blade Seal
75	500779	1	Flange, Sleeve
76	500249	1	O-Ring, Sleeve
77	002187	1	Lock Washer
78	404800	1	Flat Washer
79	501039	1	Sequential Trigger
80	501299	2	S.H.C.S. 1/4-20 x 1"

Accessories

		PSN90	PSN100
	<p>Remote Fire Valve This valve via a positive air signal allows a machine mounted tool to be operated from an automatic air valve or foot pedal system.</p>	1X0713	1X0713
	<p>Trigger Valve Kit Repairs trigger valve air leaks</p>	219224	219224
	<p>No-Mar Work Contacting Element W.C.E. with a rubber tip prevents you from marring wood surfaces</p>	219228	500903
	<p>No-Mar Tip Replacement tip for No-Mar Work Contacting Element</p>	501022	501022
	<p>Lubricants and Loctite Loctite 242 (Blue) 093500 093500 Lubricating Oil 16 oz 403720 403720 Lubricating Oil with Antifreeze 219090 219090 Chemplex 710 Lubricant 1 lb 403734 403734 Lubricant 5 gram tube 219188 219188</p>		
	<p>Degreaser Cleaner Ideal cleaner for all Paslode tools</p>	219086	219086
	<p>Safety Glasses Clear 402510 402510 Tinted 402512 402512</p>		

- GB** For safe operation of Paslode pneumatic tools, use only those fasteners identified in the operating manual.
- D** Für sicheres Arbeiten der pneumatischen Paslode Geräte bitte nur in der Gebrauchsanleitung spezifizierte Verbindungsmittel benutzen.
- F** Pour une utilisation en toute sécurité de vos cloueurs pneumatiques Paslode, utilisez uniquement les consommables spécifiés dans le manuel opératoire
- E** Por razones de seguridad, con las máquinas neumáticas Paslode utilice sólo los "fasteners" especificados en el manual de instrucciones de la máquina.
- NL** Voor een veilige werking van Paslode pneumatisch apparatuur; gebruik ten allen tijde alleen de voorgeschreven (zie gebruiksvorschriften) verbruiksmaterialen.
- DK** Tænk på dine kollegers og din egen sikkerhed! Anvend kun originale Paslode søm jvf. Manualen til Paslode sømpistoler.
- S** För säker användning av Paslode lufttryckverktyg, använd endast i användarmanualen angivna fästelement.
- FIN** Paslode paineilmansuimien turvallisen toimivuuden varmistamiseksi, käytäkää vain tässä käyttöohjeessa eriteltyjä nauvoja.
- N** For sikker bruk av Paslode trykkluftverktøy, må det kun brukes spiker som er angitt i instruksjonsheftet.
- P** Por questões de segurança das máquinas pneumáticas Paslode, use apenas os produtos identificados no manual de procedimentos
- I** Per utilizzare in sicurezza le chiodatrici pneumatiche Paslode, usare solo i chiodi prescritti nel libretto di uso e manutenzione.

EN792-13
European Safety Standard

For safe operation of Paslode pneumatic tools, use only those fasteners identified in the operating manual.

~~**EN792-13**
European Safety Standard~~