

ITEM NO.	PART NUMBER	REVISION	DESCRIPTION	QTY
1	PA3077	REL-01	3200 Handles (Pair)	1
2	ADD090	REL-01	Heater Housing Assy Tec 3400	1
3	PA3040	REL-01	Heater Housing Spacer	1
4	PA3035	REL-01	Rear Barrel	1
5	PA3084	REL-02	Feed Bar/Mech Assy. - 3200	1
6	PA3082	REL-01	Feed Link/Trigger Assy.	1
7	PA3083	REL-01	Snubber Assy.	1
8	PA3041	REL-01	Nozzle Shroud	1
9	AED090	REL-01	Temp Control Assy - 230V	1
10	AED091	REL-01	Temp Control Assy - 120V	1
11	ADJ023	REL-01	Nozzle Assy 3.5mm	1
12	PA3002-RD	REL-01	Handle Grip	1
13	NDN082	REL-01	Cord Clamp	1
14	NDN005	REL-02	Heavy Duty 6000 Stand	1
15	FSZ004	REL-01	Thumb Screw M6 - 20	1
16	FPD005	REL-01	Compression Spring	1
17	PA3044	REL-01	Barrel Support	1
18	PA3087	REL-01	Heater Assy. 230V	1
19	PA3086	REL-01	Heater Assy. 120V	1
20	PA6066	REL-01	UK Cordset Assy. 3 Core 3m	1
21	PA6065	REL-01	Euro Cordset Assy. 3 Core 3m	1
22	AJR036	REL-01	110v Cordset Assy 3 Core 3m	1
23	PA8022	REL-01	US Cordset Assy. 3 Core 3m	1
24	PA4028	REL-01	Earth Wire Assy.	1
25	PA3080	REL-01	Capacitor/VDR Assy. 240V	1
26	PA3081	REL-01	Capacitor/VDR Assy. 120V	1
27	PA3057	REL-01	Trigger Spring	1
28	NDN093	REL-01	Module Receptacle	1
29	AED084	REL-01	Plug-In Module 195C	1
30	AED081	REL-01	Plug-In Module Lowmelt	1
31	AED082	REL-01	Plug-In Module 160C	1
32	AED083	REL-01	Plug-In Module 180C	1
33	AED085	REL-01	Plug-In Module 205C	1
34	AED086	REL-01	Plug-In Module 215C	1
35	AED092	REL-01	Thermal Fuse Assy 3400	1
36	PA3017		Dowel Pin - 4 x 32 Lg.	1
37	PA1042		Washer 4BA Spring	1
38	PA1032		Screw 4BA x 1/4" Pozi Pan	1
39	PA3062		Dowel Pin - 6 x 26 Lg.	1
40	PA3045		Screw 4 x 12mm Plastite Pozi Pan	9
41	H019A		Screw #4 x 1/2"	2
42	FWZ017		Screw - M3 x 8 Lg Double Washer Sems	1

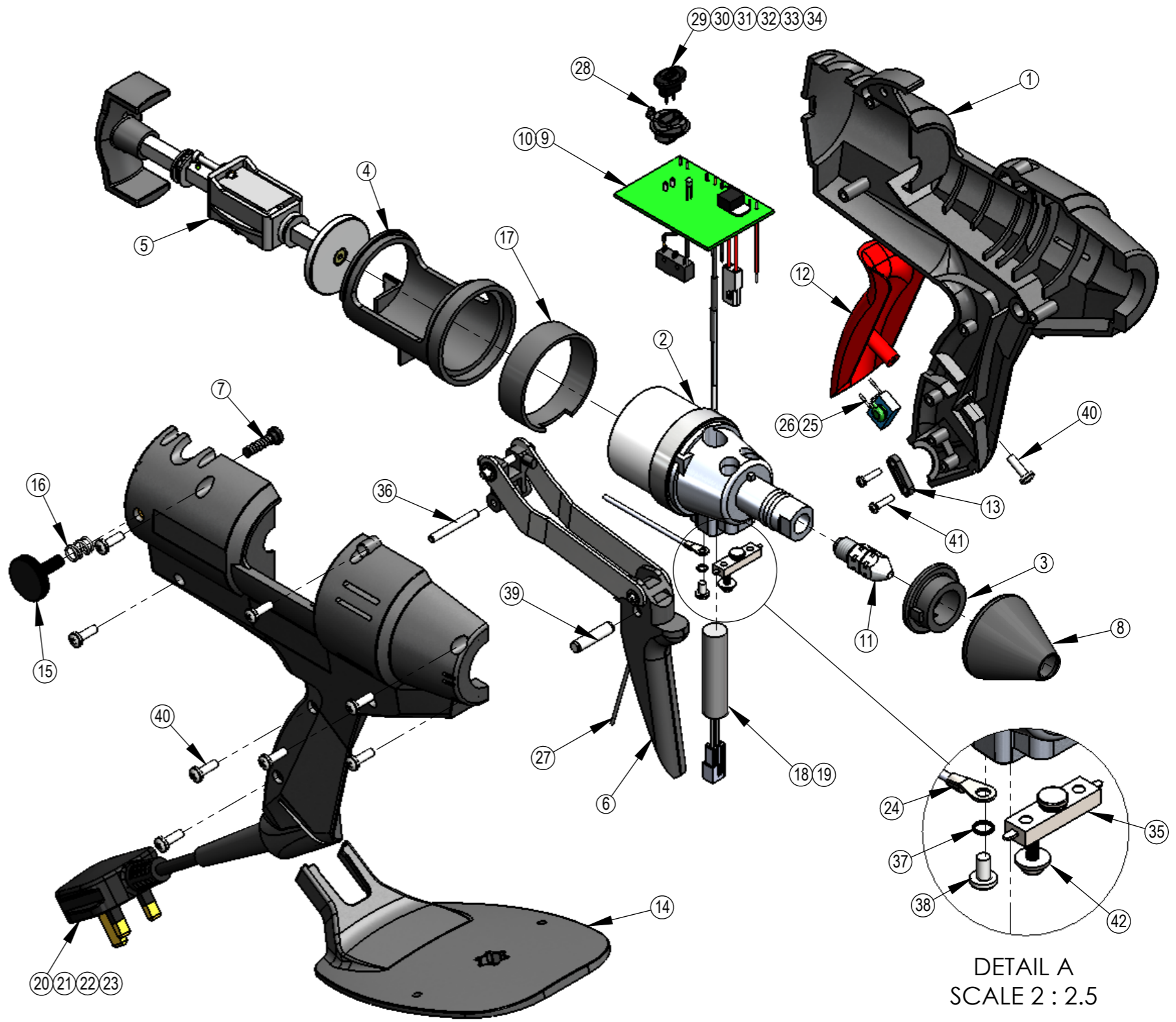

F	MATERIAL	N/A	DRAWN	SteveE	<small>DIMENSIONS ARE IN MM UNLESS OTHERWISE STATED</small>  <small>THIRD ANGLE</small>	<small>TOLERANCES UNLESS OTHERWISE STATED</small> WHOLE NUMBERS ±0.5mm 1 DECIMAL PLACE ±0.3mm 2 DECIMAL PLACE ±0.1mm	SCALE 1:1	
	FINISH	N/A	DATE	11/05/2015			SHEET 1 OF 1	
	COLOUR	N/A	ECR No.		TITLE			Tec 3400
	NOTES From Serial No. 10001			DWG. No. A3		Tec 3400		REVISION REL-01

*THIS DRAWING AND THE INFORMATION IT CONTAINS IS THE PROPERTY OF POWER ADHESIVES AND IS CONFIDENTIAL. IT MUST NOT BE REPRODUCED EITHER WHOLLY OR IN PART. ALL RIGHTS IN RESPECT OF PATENTS, DESIGNS AND COPYRIGHTS ARE RESERVED.*